

(No Model.)

4 Sheets—Sheet 1.

M. J. WIGHTMAN & E. RASMUSSEN.

DOUBLE ARC LAMP.

No. 378,818.

Patented Feb. 28, 1888.

Fig. 1.

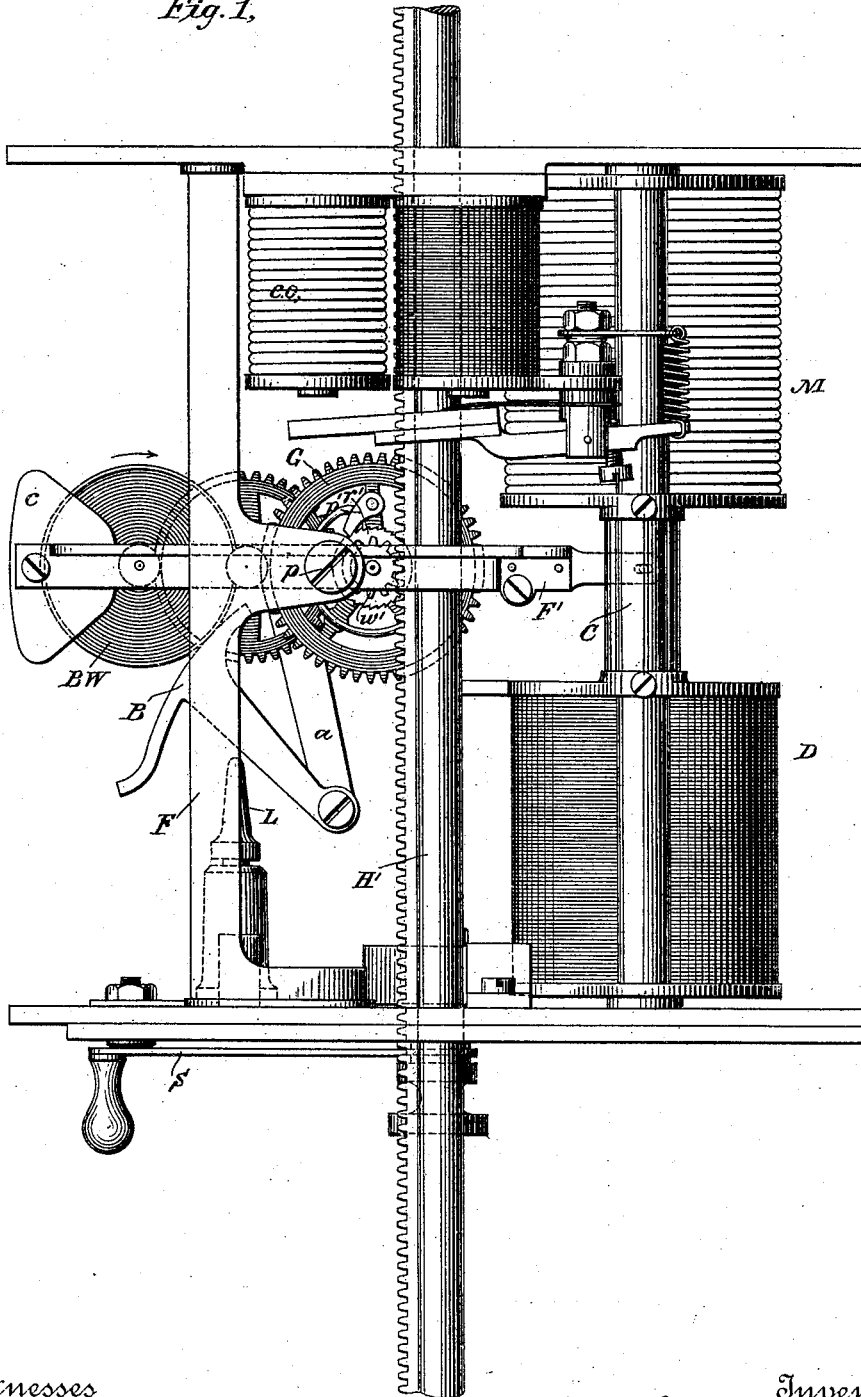

Witnesses

Geo. W. Brock  
Garni C. Ashley

Inventors

Einar Rasmussen

By their Attorneys Merle J. Wightman

Fowler & Fowler.

(No Model.)

4 Sheets—Sheet 2.

M. J. WIGHTMAN & E. RASMUSSEN.

DOUBLE ARC LAMP.

No. 378,818.

Patented Feb. 28, 1888.

Fig. 2.

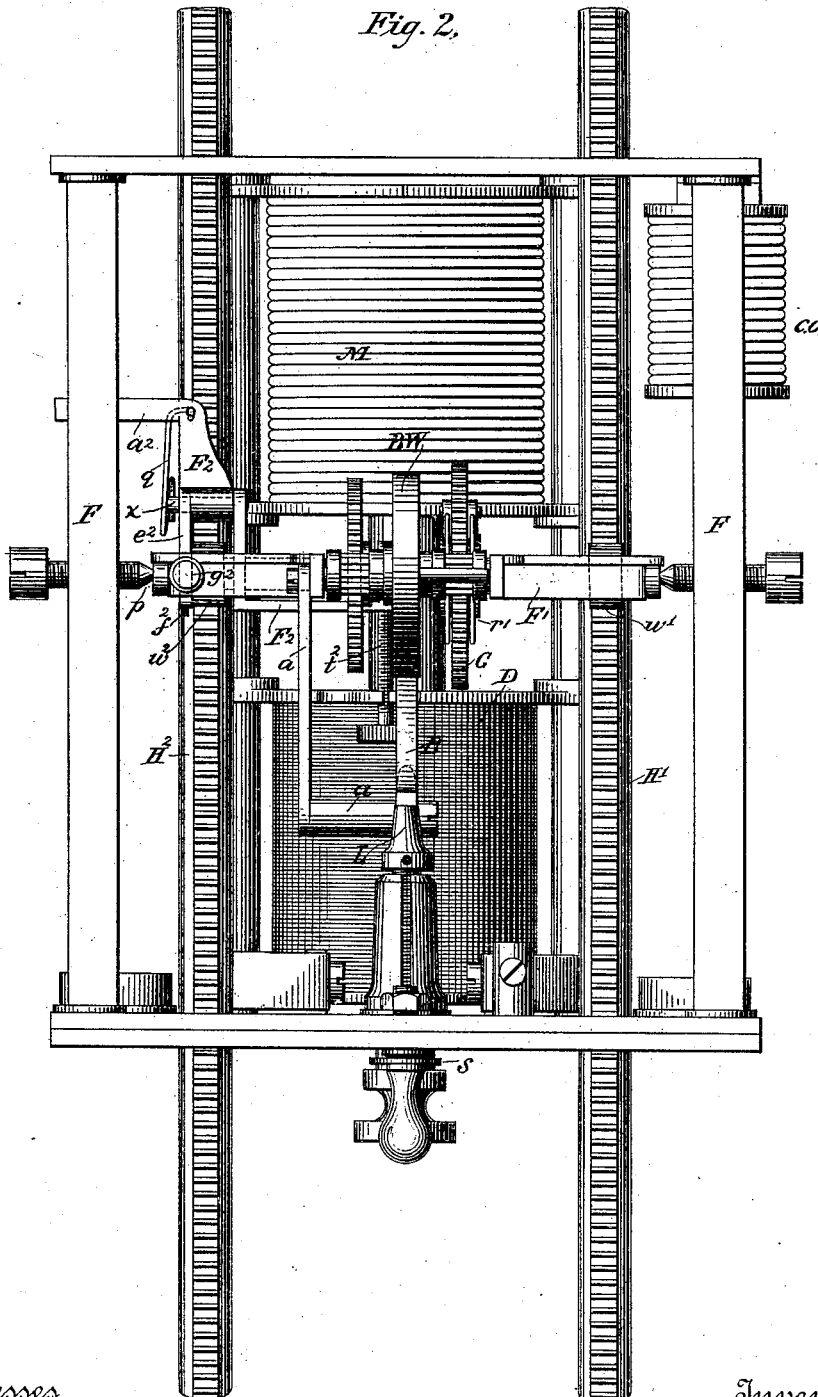

Witnesses

Geo. W. Brock  
 Carrie C. Ashley

Inventors

Einar Rasmussen  
 By their Attorneys Merle J. Wightman  
 Fowler & Fowler

M. J. WIGHTMAN & E. RASMUSSEN.

DOUBLE ARC LAMP.

No. 378,818.

Patented Feb. 28, 1888.

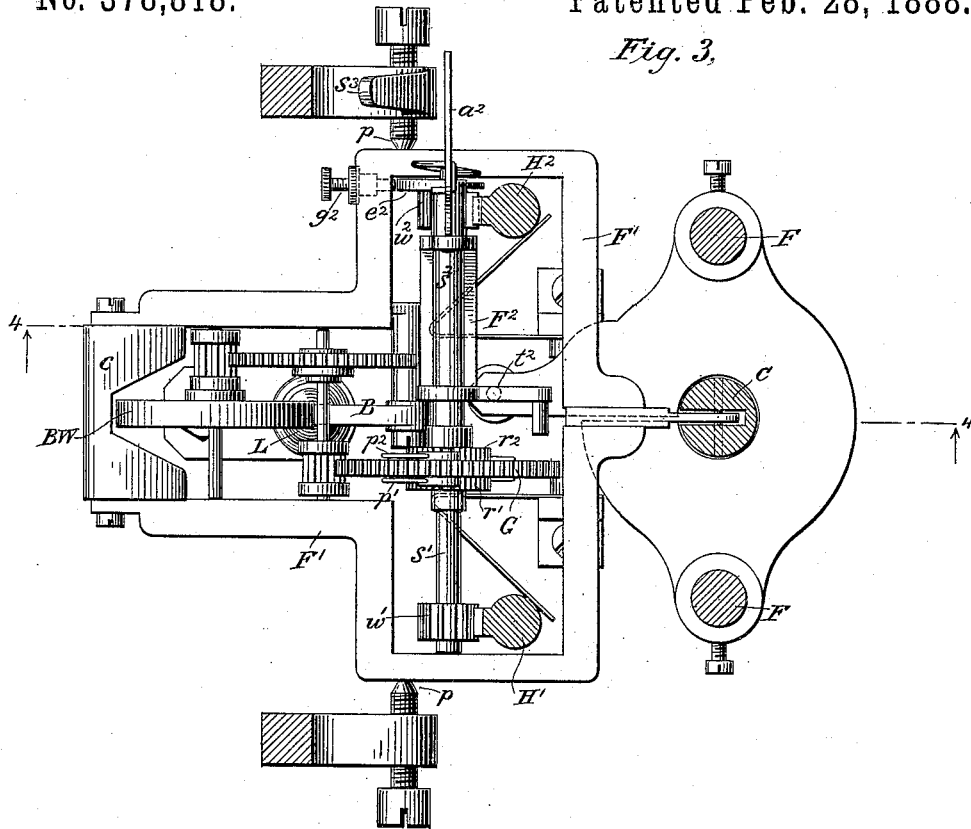

Fig. 3.

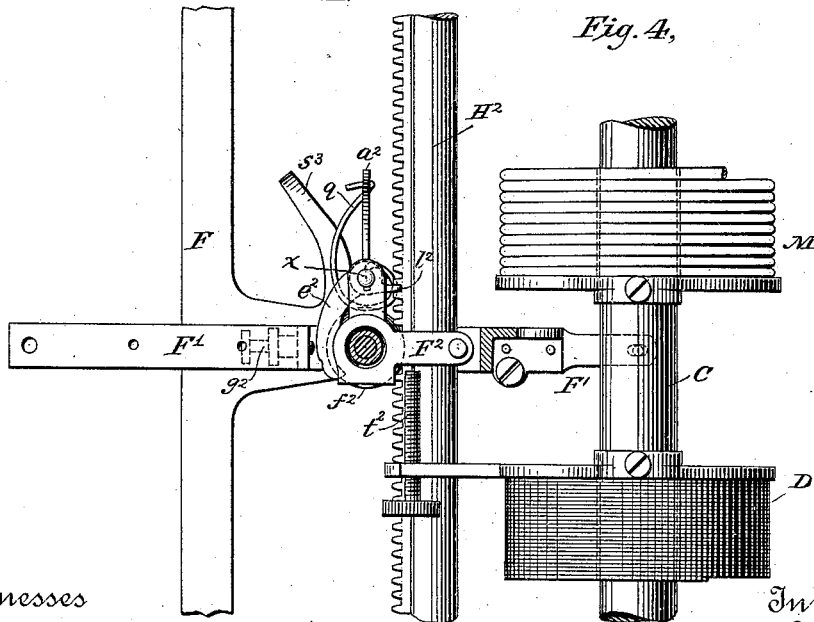

Fig. 4.

Witnesses

Geo. W. Brock  
 Carrie E. Ashley

Inventors

Einar Rasmussen  
 By their Attorneys Merle J. Wightman  
 Fowler & Fowler

M. J. WIGHTMAN & E. RASMUSSEN.

DOUBLE ARC LAMP

No. 378,818.

Patented Feb. 28, 1888.

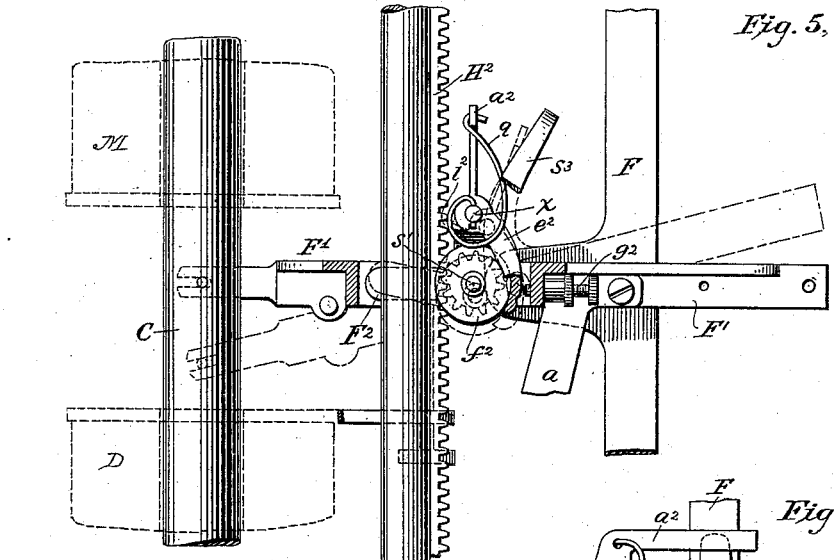

Fig. 5.

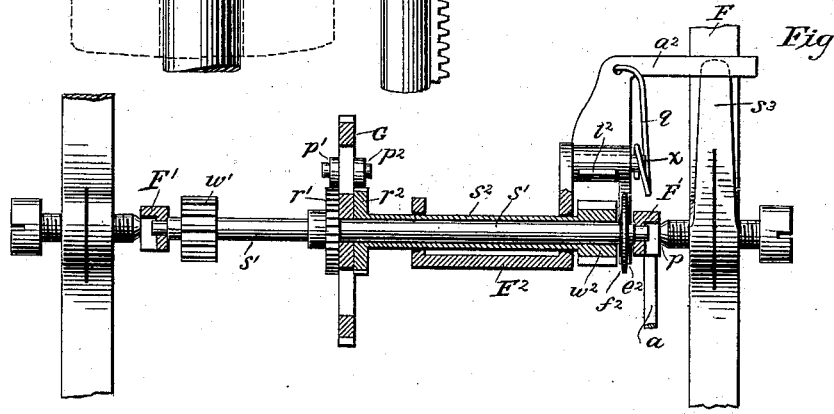

Fig. 6.

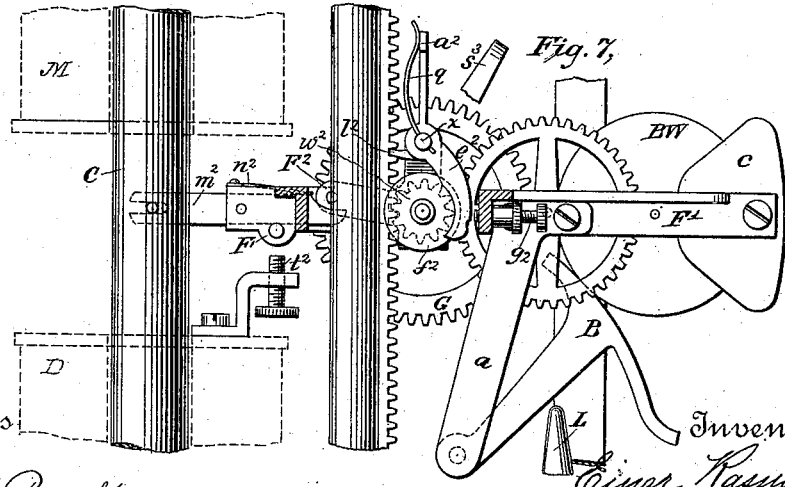

Fig. 7.

Witnesses  
 Geo. W. Breck  
 Garret E. Ashley

Inventors  
 Einar Rasmussen  
 M. J. Wightman  
 Fowler & Fowler

By their Attorneys

# UNITED STATES PATENT OFFICE.

MERLE J. WIGHTMAN AND EINAR RASMUSSEN, OF HARTFORD,  
CONNECTICUT.

## DOUBLE-ARC LAMP.

SPECIFICATION forming part of Letters Patent No. 378,818, dated February 28, 1888.

Application filed August 19, 1886. Serial No. 211,270. (No model.)

*To all whom it may concern:*

Be it known that we, MERLE J. WIGHTMAN, a citizen of the United States, and EINAR RASMUSSEN, a subject of the King of Norway and Sweden, both residing at Hartford, in the county of Hartford and State of Connecticut, have invented a new and useful Improved Double-Arc Lamp, of which the following is such a full, clear, and exact description as will enable any one skilled in the art to which it appertains to make and use the same.

Our invention relates to arc lamps wherein it is desired to hold one set of carbons in reserve while the other set are being consumed.

The object of our invention is to construct an arc lamp which will remain in operation longer than the so-called "single" lamps—that is to say, to provide an arc lamp which will furnish light during the entire night without needing to be replenished with carbon—and also to construct an arc lamp wherein, when the first set of carbons fail to operate or are consumed, the carbons that are held in reserve will be placed in circuit.

Our invention has also for its object the construction of such an arc lamp that will be simple and not possess any more electrical appliances than the ordinary single lamp, our object having been to dispense with all the electro-magnetic parts possible and to make the lamp mechanical in its operation rather than electrical.

The invention consists of a pivoted frame governed by the ordinary main and derived circuit magnets and supporting two carbon-holders which intermesh with pinion-wheels carried by said pivoted frame, with intermediate mechanism between said pinions, and a train of gearing for regulating the feed of the lamp, whereby either carbon-holder may be governed by the one set of gearing, and a locking device, also mounted on said pivoted frame, for holding one of said carbon-holders from operation, which device is actuated and held in engagement with said carbon-holder by the operation of the other carbon-holder, the whole co-operating with a trip or stop which liberates the carbon-holder held in reserve as the derived-circuit magnet is abnormally operated; and

it consists, also, in the details of construction, which will be hereinafter set forth.

In the accompanying drawings, forming part of this specification, in which like letters of reference indicate like parts throughout the several figures, Figure 1 represents a side elevation of our lamp, showing the carbon-holder which is first placed in circuit. Fig. 2 shows an end elevation at right angles to the plane of Fig. 1, looking from the left side of Fig. 1. Fig. 3 shows a plan view of the apparatus with the upper magnet and top portion of the frame-work removed. Fig. 4 shows a cross-section through the center of the lamp with a portion of the pivoted frame and gearing removed, looking at the apparatus toward the carbon-holder that is held in reserve. Fig. 5 is a side elevation of the apparatus on the opposite side to Fig. 2, showing the carbon-holder that is held in reserve. Fig. 6 is a detail elevation, partly in cross-section, showing the way of coupling the carbon-holders to the train of gearing and the locking device for the one that is held in reserve; and Fig. 7 is a side elevation of a modification of the apparatus with particular relation to the means for tripping the locking device.

F represents the frame of our lamp, which is adapted to support all the parts thereof. In two uprights of this frame is pivoted at *p p* a pivoted frame, *F'*, which carries two carbon-holders, *H' H''*, and has a counter-balance, *c*, for balancing said frame, which has at its other extremity an extension having a slot in it, in which works a pin of a core, *C*, controlled by two magnets, *M* and *D*, located in main and derived circuits, respectively.

The carbon-holders above referred to intermesh with two pinion-wheels, *w' w''*, the former located upon a shaft, *s'*, which is journaled in the frame *F'*, as clearly shown in Fig. 6. This shaft *s'* carries a sleeve, *s''*, which bears the other pinion-wheel for the second carbon-holder. The sleeve and shaft have keyed thereto ratchet-wheels *r'* and *r''*, which embrace a spur-wheel, *G*, loosely mounted upon the shaft. This spur-wheel has pawls *p' p''* secured thereto, which take into said ratchets. The spur-wheel is in gear with a train of gearing supported by the frame *F'*, the last wheel of which train is a

friction-wheel, B W, upon which is adapted to bear a brake, B, supported by an arm, *a*, hung from the pivoted frame, said brake B being adapted to be thrown against a let-off, L, mounted upon the base of the lamp. These latter features are clearly shown and described in Patent No. 329,461, granted November 3, 1885, to Hermann Lemp, and need no further explanation here.

It will be observed by the means of the mechanism which is shown in Fig. 6 that either carbon-holder may be placed under the controlling influence of the train of gearing by means of the spur-wheel and pawls and ratchets. Mounted upon the sleeve *s*<sup>2</sup> is another pivoted frame-piece, F<sup>2</sup>, which is of the form shown in Figs. 2, 3, and 6. This frame has a pin, *x*, surrounded by a sleeve carrying a downwardly-extending friction-brake, *e*<sup>2</sup>, which bears upon a friction-wheel, *f*<sup>2</sup>, keyed to the shaft *s*<sup>1</sup>. The frame F<sup>2</sup> has an arm, *a*<sup>2</sup>, extending therefrom, and a spring, *g*, engaging with said arm to force the friction-brake *e*<sup>2</sup> against the friction-wheel *f*<sup>2</sup>. The whole frame pivots about the sleeve *s*<sup>2</sup> and has a rest, *s*<sup>3</sup>, for keeping the frame from gravitating to its lowest position below the friction-wheel. The friction-brake *e*<sup>2</sup> has also an adjustable limiting-stop, *g*<sup>2</sup>, for limiting its play to and from the friction-wheel. This stop *g*<sup>2</sup> is mounted upon the pivoted frame F<sup>2</sup>, which carries the gearing. The pivoted frame F<sup>2</sup> has a locking-tooth, *l*<sup>2</sup>, which engages with the teeth upon the carbon-holder H<sup>2</sup>. As soon as the weight of the carbon-holder H<sup>2</sup> falls upon the tooth *l*<sup>2</sup>, the sleeve, arm *a*, and friction-brake *e*<sup>2</sup> are slightly rotated, so as to take off the friction-brake *e*<sup>2</sup> from the friction-wheel *f*<sup>2</sup>, thus taking off so much resistance to the downward movement of the carbon-holder H<sup>2</sup>. The pivoted frame F<sup>2</sup> has an extension (shown in Figs. 3 and 4) which is adapted to be drawn against a stop or adjustable trip, *l*<sup>2</sup>, which action is accomplished by the derived-circuit magnet drawing down the frame-work F<sup>2</sup> when the carbon in circuit fails to operate or has been consumed. This tilts the frame-piece F<sup>2</sup> backward and throws the locking-tooth out of engagement with the carbon-holder H<sup>2</sup>, and allows the same to be placed in circuit.

The extension-piece *e*<sup>2</sup> is grooved, and receives in this groove the periphery of the friction-wheel *f*<sup>2</sup>. As the carbon H<sup>2</sup> operates, it rotates the shaft *s*<sup>1</sup>, and thereby the friction-wheel *f*<sup>2</sup>, which tends always to force the locking-tooth into engagement with the carbon-holder H<sup>2</sup> by the friction between the two, so that it will be observed that so long as the carbon-holder H<sup>2</sup> is operated the carbon H<sup>2</sup> will be locked, and even though the carbon-holder H<sup>2</sup> be accidentally liberated by the locking-tooth *l*<sup>2</sup> slipping out of engagement therewith it will be locked again by the friction-wheel tending to push the frame F<sup>2</sup> and locking-tooth *l*<sup>2</sup> toward the holder H<sup>2</sup> as the friction-wheel is operated by the carbon-holder

H<sup>2</sup>. Either carbon-holder is thrown under the controlling influence of the gearing by the pawl-and-ratchet arrangement above referred to, so that one train of gearing serves to govern them both.

The downward movement of each carbon-holder is limited by means of a projecting pin inserted in the last tooth of the gear cut in each of said holders, which pins engage the pinion-wheels *w* and *w*<sup>1</sup> and prevent any further downward movement of the holders, thus limiting the excursion of the same and preventing the first carbon-holders from running together and short-circuiting the second pair when the carbon of the first pair has been consumed. Should this occur before the carbons of the first set of holders are consumed, the second pair would be short-circuited and the first pair put in circuit, the operation of which will hold the second pair from operation, as before. It will thus be seen that the first pair may be put in operation after failure to operate, provided the carbon is not entirely consumed. If this were the case, the pins above spoken of would prevent the first set of holders from coming in contact. In other words, the distance between the same would be too great for an arc to be formed. Thus, as the first set fail to operate from any cause, the second set will no longer be held from operation and the current will now pass through the second set.

The apparatus is provided with an ordinary cut-out, CO; but this forms no part of our invention. The apparatus is also provided with a switch, S, for putting in or cutting out the lamp, and has suitable springs bearing upon the carbon-holders H<sup>1</sup> and H<sup>2</sup> for completing the circuit through the same.

In Fig. 7 is shown a modification of our apparatus. In this figure the piece *m*<sup>2</sup> is pivoted in the pivoted frame F<sup>2</sup> and engages at one end the pin in the core C. At the other end it is curved and engages a pin on the pivoted frame-piece F<sup>2</sup>, and has a spring, *n*<sup>2</sup>, for holding it down against a stop. The trip *l*<sup>2</sup> is also shown, and may be of the usual construction. The operation of this modification is substantially the same as the apparatus described in the foregoing figures. The magnets M and D operate the apparatus, as usual; but when the arc becomes abnormally long the derived-circuit magnet draws down the core more than usual and brings the frame F<sup>2</sup> against the stop *l*<sup>2</sup>. Any further movement of the core overcomes the tension of the spring *n*<sup>2</sup>. The piece *m*<sup>2</sup> swings upon its pivot and trips the frame-piece F<sup>2</sup>, which throws the locking device out of engagement with the carbon-holder H<sup>2</sup> and permits it to come into operation.

The operation of the apparatus is as follows: Normally both sets of carbons are together. When the current flows, both carbon-holders are lifted and H<sup>2</sup> is locked in its raised position by the operation of H<sup>1</sup>. The magnets M and D operate the carbon-holder H<sup>1</sup> in the or-

dinary way until this fails to operate, or until the carbons carried thereby become consumed, when the arc grows abnormally long, the magnet D has more than its usual current of electricity thrown upon it, it draws the frame-work F' downward beyond its ordinary range, and brings the frame-piece F<sup>2</sup> against the stop or trip t', which tilts this frame-work backward and throws the locking-tooth out of engagement with the carbon-holder H<sup>2</sup> and permits it to start into operation. As the carbon-holder H' has discontinued its operation, and the friction-wheel f<sup>2</sup> has therefore stopped rotating, there is no tendency for the locking-tooth to seek engagement with the holder H<sup>2</sup>, even though the frame F' resumes its normal position and operation. The rest S<sup>3</sup> holds the locking devices in the position shown in the dotted lines shown in Fig. 5, so that should the friction-wheel begin to rotate the locking device will be thrown immediately into engagement with the carbon-holder H<sup>2</sup>.

Should the first set of carbons run together after the second set have been put in circuit by the failure of operation of the former, the latter will be short-circuited and the first carbon put in circuit, the operation of which will automatically lock the second set, holding them in reserve, as before. As the spindle s' and sleeve s<sup>2</sup> are free to rotate independently and are provided with the devices described for coupling each to the train of gearing, it will be observed that the carbon-holders may be independently operated and that the action of one does not interfere with the action of the other.

Having now fully set forth our invention and its operation, we wish to make it known that we do not desire to limit ourselves to the exact construction set forth, as the construction may be varied without departing from our invention, and we reserve the right in practice, should we see fit, to make all such changes as fall within the spirit and scope of the invention; but

What we desire to claim and secure by Letters Patent is—

1. The combination, in a double-arc lamp, of a main and derived magnet controlling the length of the arc, two carbon-holders, and a locking-tooth holding one in reserve, operated by the aforesaid magnets that control the arc for putting the second in circuit.

2. The combination, in a double-arc lamp, of two carbon-holders, one of which is adapted to be brought into operation first, two sets of carbons carried thereby, a locking-tooth holding the second out of operation, and a friction-gear operated by the first carbon-holder to keep said locking-tooth in engagement with the second.

3. In a double-arc lamp, a pivoted frame carrying a train of gearing for regulating the feed of the lamp, two carbon-holders supported thereby, a locking device, also mounted on said pivoted frame, for holding one of said carbon-holders out of operation, and a trip for throw-

ing said locking device out of engagement with said holder and putting it in operation as said pivoted frame becomes abnormally tilted.

4. In a double-arc lamp, a supplemental carbon-holder, a locking device therefor, gearing co-operating therewith actuated by the operation of the carbon-holder proper for holding said locking device in engagement with said supplemental carbon-holder, and a liberating mechanism or trip for actuating said locking device in opposition to the means holding it in engagement with said supplemental carbon-holder.

5. In a double-arc lamp, a supplemental carbon-holder, a locking device therefor, a friction-wheel actuated by the carbon-holder proper, operating the latter for holding it in engagement with said supplemental carbon-holder, a spring for keeping the two in contact, and means for liberating said supplemental carbon-holder after the carbon-holder proper stops operating.

6. In a double-arc lamp, a supplemental carbon-holder, a locking device therefor, a friction-wheel actuated by the carbon-holder proper, operating the latter for holding it in engagement with said supplemental carbon-holder, a spring for keeping the two in contact, an adjustable stop for limiting the play of the locking device, and means for liberating said supplemental carbon-holder after the carbon-holder proper stops operating.

7. The combination, in a double-arc lamp, of a pivoted frame carrying a gear feeding and brake mechanism and supporting two carbon-holders, a spindle journaled in said frame carrying a sleeve loosely thereon, pinion-wheels on said spindle and sleeve near each end intermeshing with said carbon-holders, respectively, a spur-wheel loosely mounted upon said spindle intermediate of said pinions, pawls and ratchets co-operating therewith for coupling either carbon-holder to the gear feeding and braking mechanism, a second pivoted frame swung upon said sleeve and carrying a locking-tooth for one of said carbon-holders, a friction-wheel secured to said spindle, upon which friction-wheel bears an extension of said second pivoted frame for operating it to throw the locking-tooth in engagement with said carbon-holder as the spindle is rotated by the other one, and a device for throwing said locking-tooth out of engagement with said carbon-holder to put it in operation when the pivoted frame carrying the aforesaid gearing is abnormally operated.

8. The combination, in a double-arc lamp, of a gear feeding mechanism, two carbon-holders, a spindle having a pinion-wheel thereon, forming a part of said gear feeding mechanism for one carbon-holder, a sleeve loosely mounted upon said spindle, having thereon a pinion-wheel for the other carbon-holder, a spur-wheel loosely mounted upon said spindle, pawls and ratchets for coupling either carbon-holder to the gear feeding mechanism, a frame free to vibrate carrying a locking-tooth for the latter

carbon-holder, a device for keeping the frame and locking-tooth in operative position to lock said carbon-holder by the operation of the other one, and an adjustable trip for throwing the locking-tooth and frame out of operative position to liberate the second carbon-holder.

9. In a double-arc lamp, a supplemental carbon-holder, a friction-wheel actuated by the operation of carbon-holder proper, a locking device for said supplemental carbon-holder, kept in engagement therewith by said friction-wheel, means for throwing the same out of engagement with said supplemental carbon-holder to allow it to come into operation, and a rest for the locking device to keep it in a position to be operated.

10. In a double-arc lamp, a supplemental carbon-holder, a friction-wheel actuated by the operation of carbon-holder proper, a locking device for said supplemental carbon-holder, kept in engagement therewith by said friction-wheel, means for throwing the same out of engagement with said supplemental carbon-holder to allow it to come into operation, a rest for the locking device to keep it in a position to be operated, and an adjustable stop for regulating its play.

11. In a double-arc lamp, two sets of carbons, an electro-magnet in a constantly-closed derived circuit which controls the arc formed between the first set, a trip, and devices for putting the second set in action, brought in contact with said trip by the same magnet which governs the arc when it becomes abnormally long.

12. In a double-arc lamp, two sets of carbons, one of which is held in reserve by a lock-

ing-tooth, a trip upon the frame of the lamp, and an arc-controlling electro-magnet the coils of which are in a constantly-closed derived circuit for putting the second set in action.

13. In a double-arc lamp, two sets of carbons, an ordinary arc-controlling main-line magnet, a locking-tooth for holding one set of carbons in reserve, a trip, and an ordinary arc-controlling derived-circuit magnet whose coils are in a constantly-closed circuit for disengaging said locking-tooth.

14. The combination, in a double-arc lamp, of the magnets M and D in main and derived circuits, respectively, the pivoted frame F', carrying the train of gearing and friction-wheel and bearing a counterpoise, c, a let-off, L, upon the base of the lamp, two carbon-holders, H' and H<sup>2</sup> carried by said pivoted frame F', pinion-wheels w' and w<sup>2</sup> therefor upon the shaft s' and sleeve s<sup>2</sup>, respectively, means for coupling the shaft or the sleeve to said train of gearing, a friction-wheel, f<sup>2</sup>, upon said shaft s<sup>2</sup>, a locking mechanism for the carbon-holder H<sup>2</sup>, mounted upon the pivoted frame F' and bearing upon the friction-wheel f<sup>2</sup>, a spring for holding the two together, a rest, s<sup>3</sup>, for said locking mechanism, and an adjustable stop, g<sup>2</sup>, for limiting its play.

In testimony whereof we have hereunto set our hands and seals, this 28th day of July, 1886, in the presence of the subscribing witnesses.

MERLE J. WIGHTMAN. [L. S.]  
EINAR RASMUSSEN. [L. S.]

Witnesses:

HERMANN LEMP,  
WM. E. SHEPARD.