

Feb. 5, 1952

F. L. CATOR ET AL  
ELECTRIC LIGHTING FITTING HAVING THE LAMP AND CONTROL  
ELEMENTS THEREFOR REMOVABLE AS A UNIT  
Filed July 30, 1946

2,584,671

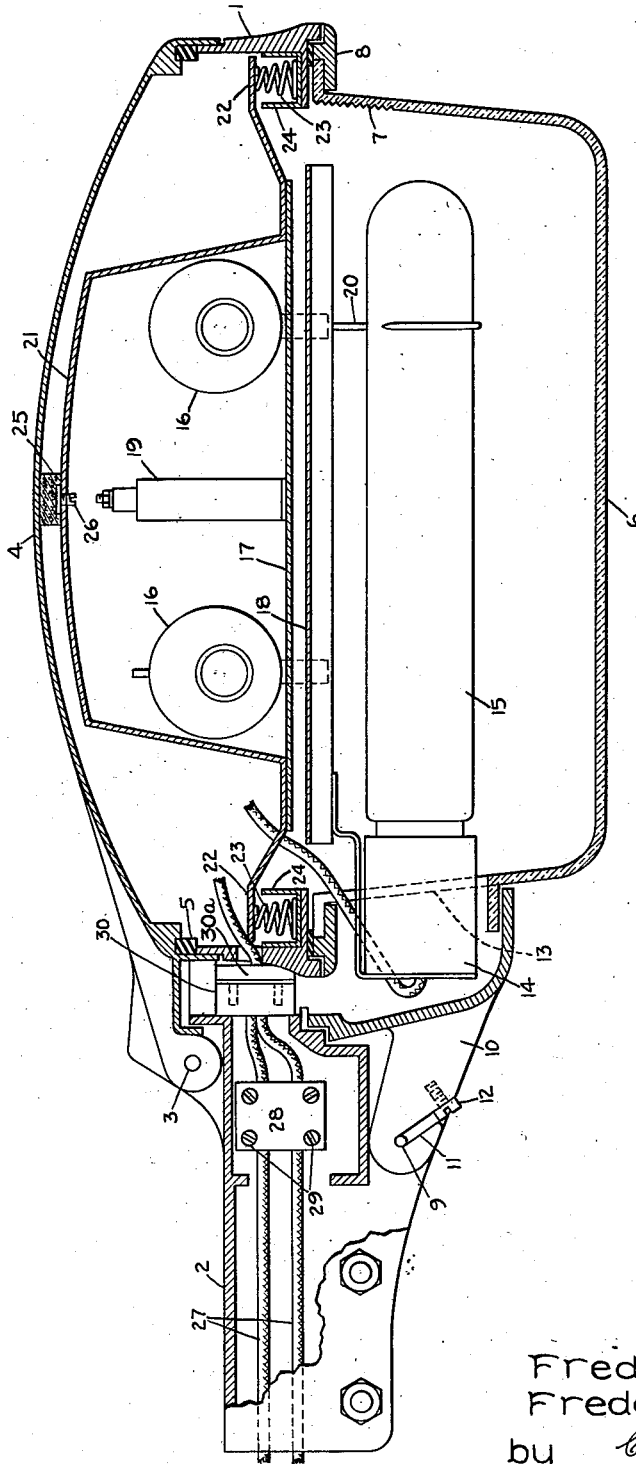

Inventors:  
Frederick L. Cator,  
Frederick W. Thorpe,  
by *Claude F. Mitt*  
Their Attorney.

## UNITED STATES PATENT OFFICE

2,584,671

ELECTRIC LIGHTING FITTING HAVING THE  
LAMP AND CONTROL ELEMENTS THERE-  
FOR REMOVABLE AS A UNIT

Frederick L. Cator, Olton, and Frederick William  
Thorpe, Birmingham, England, assignors to  
General Electric Company, a corporation of  
New York

Application July 30, 1946, Serial No. 687,198  
In Great Britain August 3, 1944

Section 1, Public Law 690, August 8, 1946  
Patent expires August 3, 1964

1 Claim. (Cl. 240—11.4)

1

This invention relates to electric lighting fittings adapted for use in the open, where they are exposed to the weather, and particularly to street lighting fittings. The invention is especially concerned with totally enclosed fittings provided with a side entry for the supply conductors and for supporting the fitting.

The object of the invention is to provide a construction of such fittings which is simple to manufacture and install, and the interior of which is readily accessible for cleaning.

A totally enclosed side entry electric lighting fitting, according to the invention, comprises a base member of ring formation adapted to receive a translucent or transparent bowl or like light control device which encloses the lower face thereof, the base member having at its periphery hollow means for attaching it to a support and for leading supply conductors thereinto, a cover member hinged to the support and adapted to enclose the upper face of the base member, and a detachable lighting unit fitting into the base member and including the source of light.

The source of light preferably consists of electric discharge lamp which is horizontally mounted together with the necessary magnetic means for controlling the discharge within the lamp.

An important feature of the invention resides in rendering the light source within the fitting completely removable as a unit with its control elements. For this purpose, when employing a horizontally mounted electric discharge lamp, we provide a lighting unit comprising a sub-base member onto which the discharge lamp and control elements are mounted, the control elements being above the sub-base member and the lamp below it. The lamp is mounted in a socket so connected to the sub-base member that the lamp lies parallel thereto. Above the lamp and below the sub-base member we provide a reflector suitably shaped to direct the light from the lamp downwardly through the bowl. The control elements mounted above the sub-base member may consist of a series choke and condenser suitably connected, the choke being arranged to provide a magnetic field to maintain the arc in the lamp centrally within the envelope in a manner well known per se. The sub-base member may be provided with a handle to enable it readily to be removed from the base member.

In order to isolate the lighting unit from vibration, the sub-base member is preferably supported on springs or other resilient means which are located in suitable channels or lugs extending from the base member, the springs being engaged

2

by extensions from the sub-base member. By thus supporting the lighting unit, we ensure that the relative positions of the lamp and its reflector remain unchanged with any small relative movement between the sub-base member and the main base a support member.

We will now describe, with reference to the accompanying drawing, an embodiment of the invention, the drawing showing the said embodiment in cross section.

Referring to the drawing we have illustrated a base member 1 having at its periphery a hollow clamping member or mounting bracket 2 adapted to be secured to a suitable support which may be the termination of a concrete or other pillar. The base member 1 is shaped in accordance with the desired form of the fitting in plan, e. g., if the fitting is circular in plan the base member will consist of an annular support while for a rectangular fitting the base member will be in the form of a hollow rectangle. For the use to which the present fitting is adapted a rectangular form of base member is preferred. At the upper side of the clamping member 2 is formed a hinge connection 3 for the upper cover member 4 of the fitting. The hinge may be formed in any convenient manner, for example, by means of two lugs arranged to receive the pin forming the hinge pin for the cover member 4. The cover member is shaped so that when it is lowered onto the base member 1 it forms a complete enclosure for the upper face thereof. A gasket 5 serves to provide a moisture tight joint between the cover member 4 and the base.

The lower face of the base member 1 is enclosed by a translucent bowl 6. This is shown as being provided on its inner face with refracting elements 7 suitably formed to provide the desired light transmitting characteristics. The bowl 6 may be directly supported on the base member 1 for example by having a peripheral projection adapted to engage with a ledge formed on the lower rim of the base member 1. However, in the embodiment illustrated we support the bowl on a lower ring 8 hinged at 9 on the projection 2 so that the bowl can readily be lowered if desired for cleaning purposes. The hinge is shown as being so constructed that after the ring 8 has been swung away from the base member to a predetermined angular degree, the ring may be detached from the hinge pin on which it is supported. To this end the hinge is formed by a projection 10 on the ring 8, the projection being provided with a slot 11 so angularly positioned that it is only releasable from the pin

3

when the ring 8 is swung round to an angle somewhat greater than 90°. A grub screw 12 may be inserted to obscure the end of the slot 11 and prevent removal of the ring 8 until the screw has been removed.

The bowl 6 is provided with a U-shaped slot in its periphery at 13 to allow for the positioning of the holder 14 for a lamp 15. The lamp 15 is of the electric discharge type and is horizontally mounted in the fitting. To maintain the arc centrally within the lamp envelope, magnetic arc control coils 16 are provided in known manner. These are supported on the upper face of a sub-base member 17 from the lower face of which the holder 14 and the lamp 15 are supported. The sub-base member 17 may also support a reflector 18. A power factor control condenser 19 is supported midway between the magnetic control devices 16. The outer end of the lamp 15 may be supported from the sub-base member 17 by a spring clip 20. By the use of the sub-base assembly for the lamp and magnetic control devices and the reflector these parts are held in accurate relationship with one another.

The sub-base member 17 with its associated parts is removable as a whole from the fitting when the cover member 4 is raised to expose the interior thereof and has a handle 21 provided for this purpose. The sub-base member 17 is also supported resiliently within the fitting by providing it with lugs 22 of which there may be four in number, two at each end, these lugs being supported on shock absorbing supports indicated as springs 23 set in sockets 24 mounted on the base member 1. On the closure of the cover member 4 the inner face thereof is adapted to bear on the handle 21 and compress the springs 23 thereby positioning the sub-base member and its associated devices within the fitting. A felt pad 25 is preferably located beneath the cover member 4 to engage the handle 21 to assist in the resilient support of the sub-base member 17. Compression of the springs may be rendered adjustable by means of an adjusting screw 26 mounted on the handle of the side which engages the pad 25.

The hollow mounting bracket 2 also provides a means for the entry of supply conductors 27 in the fitting. The supply conductors are taken to a connecting plate 28 the terminal screws 29 on which are accessible by removing a cover plate fixed on the outside of the clamping member. Connections from the terminals 29 are taken to a two-part detachable plug connector 30, 30a which provides the necessary releasable connection between the detachable sub-base assembly and the supply conductors.

The upper cover member 4 and the ring 8 supporting the bowl 6 are provided around their periphery with suitably spaced locking means for securing them rigidly in position.

4

It will thus be seen that we have provided a fitting, the necessary maintenance portions of which are capable of being readily removed, the complete lighting unit being removable from the inside of the fitting when the cover 4 is hinged open, whilst the bowl alone may be cleaned by hinging back the ring 8.

What we claim as new and desire to secure by Letters Patent of the United States is:

A totally enclosed side entry electric lighting fitting comprising, a base member of ring formation having interior mounting seats fixed thereto, a hollow mounting bracket attached to the periphery of said base member and extending radially outward therefrom, a first electric plug connector mounted within said bracket, a light transmitting closure member hingedly mounted upon said bracket and arranged to enclose one face of said base member, a sub-base resiliently mounted upon said interior seats and extending diametrically across the interior of said ring-shaped base member, an elongated reflector fixed to said sub-base on the side adjacent said closure member and disposed diametrically across said base member, a lamp receptacle supported by said sub-base in a position to mount an elongated arc discharge lamp in parallel spaced relation with said reflector, a second electric plug connector electrically connected to said lamp mounting receptacle and adapted to cooperate with said first plug connector, electric arc control means mounted upon the other side of said sub-base in position to control the arc in said discharge lamp, and a cover member hingedly mounted upon said bracket and arranged to enclose the other face of said base member, whereby, said sub-base divides said totally enclosed fitting into a lower lamp compartment and an upper control compartment and constitutes with said lamp reflector and receptacle and said control means an integral lighting unit removable from said base member without disassembly.

FREDERICK L. CATOR.

FREDERICK WILLIAM THORPE.

#### REFERENCES CITED

The following references are of record in the file of this patent:

#### UNITED STATES PATENTS

Number	Name	Date
1,318,062	Englund et al.	Oct. 7, 1919
1,741,965	Yates	Dec. 31, 1929
1,759,030	Wulle	May 20, 1930
1,772,810	Jefferson	Aug. 12, 1930

#### FOREIGN PATENTS

Number	Country	Date
183,320	Switzerland	June 16, 1936
385,495	Great Britain	Dec. 29, 1932
541,505	Great Britain	Nov. 28, 1941