

No. 627,239.

Patented June 20, 1899.

D. J. PRENDERGAST.  
STREET LAMP.

(Application filed Mar. 31, 1898.)

(No Model.)

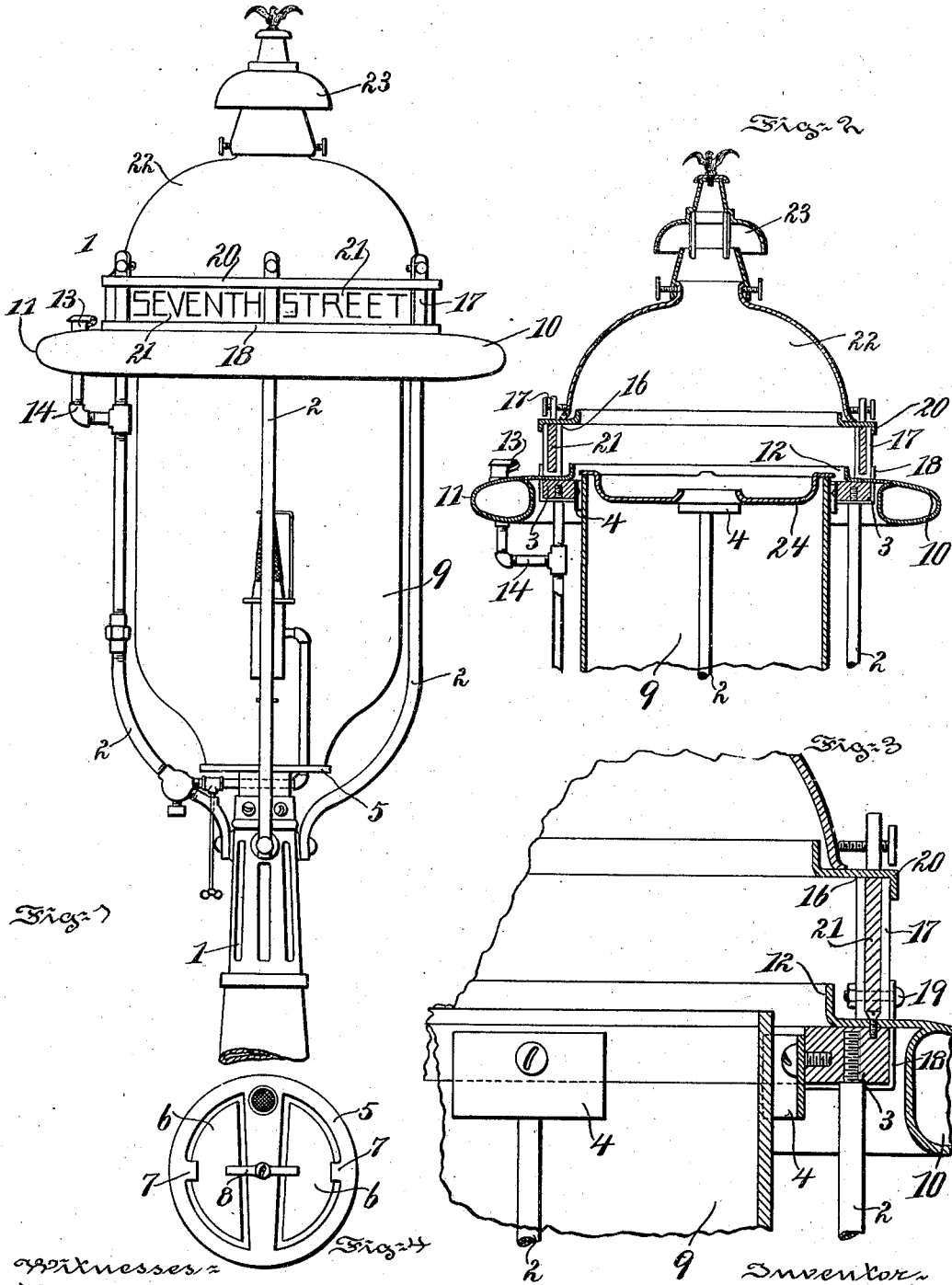

Witnesses =  
 W. B. Jackson  
 C. A. Gilligan

Inventor  
 Daniel J. Prendergast  
 By  
 Augustus B. Stouten  
 Attorney

# UNITED STATES PATENT OFFICE.

DANIEL J. PRENDERGAST, OF NEW YORK, N. Y., ASSIGNOR TO THE  
PENNSYLVANIA GLOBE GAS LIGHT COMPANY, OF PHILADELPHIA,  
PENNSYLVANIA.

## STREET-LAMP.

SPECIFICATION forming part of Letters Patent No. 627,239, dated June 20, 1899.

Application filed March 31, 1898. Serial No. 675,897. (No model.)

*To all whom it may concern:*

Be it known that I, DANIEL J. PRENDERGAST, a citizen of the United States, residing at the city of New York, in the county of New York and State of New York, have invented certain new and useful Improvements in Street-Lamps, of which the following is a specification.

The object of my invention is to provide a neat, attractive, and slightly hydrocarbon street-lamp in which the oil-reservoir is rendered comparatively inconspicuous; and to these ends my invention comprises the improvements hereinafter described and claimed.

The nature, characteristic features, and scope of my invention will be more fully understood from the following description, taken in connection with the accompanying drawings, forming part hereof, in which—

Figure 1 is an elevational view illustrating a lantern embodying features of my invention. Fig. 2 is a sectional view illustrating the upper portion thereof. Fig. 3 is a sectional view drawn to an enlarged scale and illustrating details of construction, and Fig. 4 is a top view of the bottom part of the lantern.

In the drawings, 1 is a lamp-support, from which rise standards 2 and of which four are shown, although the number may be increased or diminished, as desired. On top of the standards is mounted a ring 3, from the inner face of which spring-fingers 4 project. Upon the top of the lamp-support 1 is mounted the bottom 5 of the lantern. It may comprise a ring provided with flanges and a diametrically-arranged cross-piece and glasses 6, resting on the flanges and held to place under lugs 7 and by means of a turn-button 8. The bottom part 5 of the lantern is supported on top of the lamp-post 1. The glasses 6 rest upon and are held up by the flanges that project from the ring that constitutes part of the bottom and from the cross-piece. The flanges are shown in full lines in Fig. 4, because the glasses are transparent. The lugs 7 and button 8 overlie the glasses and prevent their accidental upward displacement, and since the button may be turned the glasses may be de-

tached. The globe 9 is guided by the spring-fingers 4 and supported by the bottom 5. These fingers are the ends of springs having the form of arcs of a circle, or substantially that form. The middle of one spring is shown beneath the head of a screw in Fig. 3, and one of the ends of the same spring is shown by dotted lines in said figure as curving inward into contact with the globe. The globe may be elevated in order to obtain access to the burner for the purpose of adjusting it and the like and then replaced upon the bottom 5. The spring-fingers 4 tend to prevent accidental breakage of the globe during these operations.

10 is an annular oil-reservoir which may be brought somewhat to an edge, as at 11. This reservoir is provided with inwardly-projecting arms or a flange 12, which is carried by the ring 3, so that the reservoir encircles the lantern and adds a sort of inconspicuous finish to its upper portion. The reservoir is provided with the usual inlet, as 13, and the supply-pipe 14 is coincident or coextensive for the greater portion of its length with one of the standards 2. Thus the supply-pipe 14, as well as the reservoir, is practically concealed. Above the flange 12 rises a series of posts 17. These are supported by stays 18, that extend upward from under the ring 3, through the flange 12, and are then connected to the posts, as by bolts or screws 19. On top of these posts rests a flanged ring 20, slotted in such manner that the posts 17 extend up through it, while shoulders, as 16, underlie and support it. Between the posts extend sections 21, which may be made of glass and arranged so as to display the names of streets and the like. On top of the flanged ring 20 is mounted a dome 22, which may be of translucent material and which carries the wind-cap 23.

24 is a centrally-perforated deflector provided with feet which rest on top of the globe. The presence of the feet insures an opening through which air may pass between the outer periphery of the deflector and the inner periphery of the globe.

It will be obvious to those skilled in the art to which my invention appertains that

modifications may be made in details without departing from the spirit thereof. Hence I do not limit myself to the precise construction and arrangement of parts hereinabove set forth, and illustrated in the accompanying drawings; but,

Having thus described the nature and objects of my invention, what I claim as new, and desire to secure by Letters Patent, is—

1. The combination of a lantern provided near its top with a ring, an annular reservoir encompassing the lantern and provided with an inwardly-extending flange adapted to said ring, and a dome or superstructure mounted on said flange, substantially as described.

2. The combination of a lamp-support, standards rising therefrom, a ring secured and attached to the top of said standards and provided with inwardly-extending spring-fingers, a lantern-bottom carried by the lamp-support, a movable globe guided by the fingers, and a dome and its accessories carried by said ring, substantially as described.

3. The combination of a lamp-support, standards rising therefrom and provided at their upper ends with a ring, an annular flanged reservoir carried by said ring, and a supply-pipe extending from the reservoir to

the burner of the lamp and coincident with one of said standards, substantially as described.

4. The combination of a ring provided with fingers carried by standards rising from a lamp-support, a bottom carried by the lamp-support, a movable globe guided by the fingers and adapted to the bottom, an annular reservoir carried by the ring and provided with a supply-pipe and burner, posts extending upward from the ring, a flanged ring supported by said posts and slotted for their passage, translucent parts 21, interposed between said rings, and a dome and its accessories carried by the flanged ring, substantially as described.

5. The combination of a lantern provided with a ring, and an annular reservoir provided with an inwardly-extending flange adapted to said ring, substantially as described.

In testimony whereof I have hereunto signed my name.

DANL. J. PRENDERGAST.

In presence of—  
C. D. HERRING,  
W. WALTER.